

NATIONAL CEMENT S.C. BIDDING DOCUMENTS
For the
SUPPLY AND DELIVERY OF TWO HUNDRED TWENTY (220)
UNITS OF SEMI TRAILER TRUCKS

JANUARY 2017

Bidding Document No: NCSC- 0001/18

Contents

Section I: INVITATION TO BID (ITB)	3
Section II: <i>Instruction to Bidders</i>	4
Section III: Bid Data Sheet (BDS)	18
Section IV: <i>General Conditions of Contract</i>	19
Section V: Special Conditions of Contract	30
Section VI: Schedule of Requirements	31
Section VII: Technical Specifications	31

Section I: INVITATION TO BID (ITB) FOR PROCUREMENT OF SEMI TRAILER TRUCKS

1. **National Cement Share Company (NCSC)** intends to procure, through open competitive tendering, Semi-Trailer trucks with corresponding consumable spare parts and Field Kits, with the budget it approved for the FY 2017/18.
2. Therefore, NCSC hereby invites bids, for the procurement of 220 Semi-Trailer trucks with corresponding two years consumable spare parts and Field Kits sufficient for two years consumption.
3. Goods specified in clause-2 above are expected to be delivered in one lot the latest by February 11/2018. Bidders are required to have completed, within the last three years (3 years) from the date of submission and receipt of bids, a contract similar to the project. The description of an eligible bidder is contained in the bidding documents, particularly, in section - 2, Instruction to bidders.
4. Bidding will be conducted through open competitive bidding procedure using a non-discretionary “pass/fail criterion (for pre-evaluation qualification) and through technical and Financial evaluation (for selection of Lowest Evaluated Bidder).
5. Bidding is open to eligible bidders (Private or Public Limited, Share Companies and Joint Ventures) of both Ethiopian and foreign companies.
6. A complete set of bidding documents may be acquired by interested bidders during the bid floating period, from our website www.nationalcementsc.com/bids;
8. Interested bidders may obtain further information via the following addresses: alemayehu.negussie@nationalcementsc.com, abdurehman.seid@nationalcementsc.com, Cellphone - +251 935 985 083/ +251 930 283 483
9. Bids must be duly received by NCSC at the following address:

foreign.purchase@nationalcementsc.com

or

**National Cement Share Company
Ethio-China Friendship Road Wello sefer, KT-12 Building**

1st floor

Tel: +251 11 4 42 19 28/ +251 25 2 11 00 70

Cell: +251 935 985 083/+251 930 179 604

Addis Ababa, Ethiopia

On or before February 11/2018 at 9:00am. All Bids must be accompanied by a bid security in any of the acceptable forms and in the amount stated in ITB Clause 15.

10. Bid opening shall be on February 14, 2018 9:30 a.m. at NCSC’s office of the supply chain Department. Bids will be opened in the presence of the bidders’ representatives who choose to attend the opening. Late bids shall not be accepted.
11. NCSC reserves the right to reject any or all bids, declare a failure of bidding, or not award the contract at any time prior to contract award, without thereby incurring any liability to the affected bidder or bidders.

Section II: *Instruction to Bidders*

A. General

1. Scope of Bid

- 1.1. NCSC invites bids for the supply and delivery of the Goods as described in Section VII, Technical Specifications.
- 1.2. The name, identification, and number of lots specific to this bidding are as provided in the **BDS**. The contracting strategy and basis of evaluation of bids shall be as described in ITB Clause 25, 28 and 29.

2. Eligible Bidders

- 2.1. Unless otherwise provided in the **BDS**, all companies (national or international) who fulfil legal requirements of the country and financially and organizational requirements of this bid shall be eligible to participate in the bid;
- 2.2. For this purpose, contracts similar to the Project shall be those described in the **BDS**, and completed within the relevant period stated in the Invitation to Bid and ITB Clause 9(a) (iii7).
- 2.3. The bidder must have the financial capacity at least equal to the offered contract price and to this end the bidder must submit latest externally audited Financial Statement prior to signing of contract agreement;

3. Bidder's Responsibilities

- 3.1. The Bidder or its duly authorized representative shall submit a sworn statement in the form prescribed in Section VIII. Bidding Forms as required in ITB Clause 16.
- 3.2 **The Bidder is responsible for the following:**
 - (a) To carefully examine all of the Bidding Documents;
 - (b) To acknowledge all conditions affecting the implementation of the contract;
 - (c) To make an estimate of the facilities available and needed for the contract to be bid, if any;
 - (d) To actively seek information pertaining to the bid through inquiry and/or follow up of any amendments provided as provided under ITB Clause 6;
 - (e) To ensure that it is not "blacklisted" or barred by the Government of Ethiopia or any of its agencies, offices,
 - (f) To ensure that each of the documents submitted in satisfaction of the bidding requirements is an authentic copy of the original, complete, and all statements and information provided therein are true and correct;
 - (g) To ensure that the signatory is the duly authorized representative of the Bidder, and granted full power and authority to do, execute and perform any and all acts necessary;
 - (h) To ensure that it did not give or pay, directly or indirectly, any commission, amount, fee, or any form of consideration, pecuniary or otherwise, to any person or official, personnel or representative of NCSC;

Failure to observe any of the above responsibilities shall be at the risk of the Bidder concerned.

- 3.3. The Bidder is expected to examine all instructions, forms, terms, and specifications in the Bidding Document.
- 3.4. It shall be the sole responsibility of the Bidder to determine and to satisfy itself by such means as it considers necessary or desirable as to all matters pertaining to the contract to be bid, including: (a) the location and the nature of the buyer; (b) climatic conditions; (c) transportation facilities; and (d) other factors that may affect the cost, duration, and execution or implementation of this bid.
- 3.5. NCSC shall not assume any responsibility regarding erroneous interpretations or conclusions by the prospective or eligible bidder; However, NCSC shall ensure that all information in the Bidding Documents, including bid/supplemental bid bulletin/s issued, are correct and consistent.
- 3.6. Before submitting their bids, the Bidder is deemed to have become familiar with all existing laws, decrees, ordinances, acts and regulations of the Philippines which may affect this Project in any way.
- 3.7. The Bidder shall bear all costs associated with the preparation and submission of his bid, and NCSC will in no case be responsible or liable for those costs, regardless of the conduct or outcome of the bidding process.
- 3.8. The Bidder should note that the Procuring Entity will accept bids only from those that have paid the applicable fee for the Bidding Documents at the office indicated in the Invitation to Bid.

4. Origin of Goods

Unless otherwise indicated in the **BDS**, there is no restriction on the origin of goods other than those prohibited by a decision of the government of Ethiopia;

5. Subcontracts

- 5.1. Unless otherwise specified in the **BDS**, the Bidder may subcontract portions of the Goods to an extent as may be approved by the Procuring Entity and stated in the **BDS**. However, subcontracting of any portion shall not relieve the Bidder from any liability or obligation that may arise from the contract for this Project.
- 5.2. Subcontractors must submit the documentary requirements under ITB Clause 9 and comply with the eligibility criteria specified in the **BDS**. In the event that any subcontractor is found by the Procuring Entity to be ineligible, the subcontracting of such portion of the Goods shall be disallowed.
- 5.3. The Bidder may identify the subcontractor to whom a portion of the Goods will be subcontracted at any stage of the bidding process or during contract implementation. If the Bidder opts to disclose the name of the subcontractor during bid submission, the Bidder shall include the required documents as part of the technical component of its bid.

B. Contents of Bidding Documents

6. Bid Document Amendment

6.1. In case where NCSC finds it necessary to amend any provision of the bidding document, it shall be issued in writing at least seven (7) calendar days before the deadline for the submission and receipt of bids.

7. Clarification and Amendment of Bidding Documents

7.1. Prospective bidders may request for clarification on and/or interpretation of any part of the Bidding Documents. Such request must be in writing and submitted at the address indicated in the **BDS** at least ten (10) calendar days before the deadline set for the submission and receipt of Bids.

7.2. The supply Chain Department shall respond to the said request by issuing a Supplemental/Bid Bulletin, to be made available to all those who have properly secured the Bidding Documents, at least seven (7) calendar days before the deadline for the submission and receipt of Bids.

7.3. Supplemental/Bid Bulletins may also be issued upon NCSC's initiative for purposes of clarifying or modifying any provision of the Bidding Documents not later than seven (7) calendar days before the deadline for the submission and receipt of Bids. Any modification to the Bidding Documents shall be identified as an amendment.

7.4. Any Supplemental/Bid Bulletin issued by the NCSC shall also be posted in the company website specified for bid submission; it shall be the responsibility of all Bidders who have properly secured the Bidding Documents to inquire and secure Supplemental/Bid Bulletins that may be issued by NCSC. To this end, Bidders who have submitted bids before the issuance of the Supplemental/Bid Bulletin shall be allowed to modify or withdraw their bids, in accordance ITB clause 20;

C. Preparation of Bids

8. Language of Bids

8.1 The eligibility requirements or statements, the bids, and all other documents to be submitted must be in English. If the eligibility requirements or statements, the bids, and all other documents submitted is/are in foreign language other than English, it must be accompanied by a translation of the documents in English. The English translation shall govern, for purposes of interpretation of the bid.

9. Documents Comprising the Bid: Eligibility and Technical Components

9.1. The first envelope shall contain the following eligibility and technical documents:

Class “A” Documents

(a) Eligibility Documents –

- (i) Business License Certificate, Tax payer’s registration Certificate, VAT registration Certificate,
- (ii) Statement of all its ongoing government and private contracts, including contracts awarded but not yet started, if any, whether similar or not similar in nature and complexity to the contract to be bid; and
- (iii) Statement of Proof for Single Largest Completed Contract (SLCC) of at least one similar project, in accordance with ITB Clause 2.2, within the relevant period as provided in the **BDS**.

The two statements required shall indicate for each contract the following:

- (iii.1) name of the contract;
- (iii.2) date of the contract;
- (iii.3) contract duration;
- (iii.4) owner’s name and address;
- (iii.5) kinds of Goods;
- (iii.6) For Statement of Ongoing Contracts - amount of contract and value of outstanding contracts;
- (iii.7) For Statement of Successfully accomplished projects - amount of completed contracts,
- (iii.8) date of delivery; and
- (iii.9) end user’s acceptance or official receipt(s) or sales invoice issued for the contract, if completed, which shall be attached to the statements

Class “B” Document:

- (iv). If applicable, the Joint Venture Agreement (JVA) in case the joint venture is already in existence, or duly notarized statements from all the potential joint venture partners

(b) Technical Documents –

- (i). Bid security in accordance with ITB Clause 15. If the Bidder opts to submit the bid security in the form of a bank draft/guarantee or an irrevocable letter of credit issued by a foreign bank, it shall be accompanied by a confirmation from a Commercial Bank;
- (ii) Conformity with technical specifications, as enumerated and specified in Sections VI and VII of the Bidding Documents; and
- (iii) Sworn statement using the form prescribed in Section VIII. Bidding Forms

10. Documents Comprising the Bid: Financial Component

Unless otherwise stated in the **BDS**, the financial component of the bid shall contain the following:

- (a) Financial Bid Form, which includes bid prices and the applicable Price Schedules, in accordance with ITB Clauses 12.1 and 12.4;
- (b) Any other document related to the financial component of the bid as stated in the **BDS**.

11. Alternative Bids

- 11.1. Alternative Bids shall be rejected. For this purpose, alternative bid is an offer made by a Bidder in addition or as a substitute to its original bid which may be included as part of its original bid or submitted separately therewith for purposes of bidding. A bid with options is considered an alternative bid regardless of whether said bid proposal is contained in a single envelope or submitted in two (2) or more separate bid envelopes.
- 11.2. Each Bidder shall submit only one Bid, either individually or as a partner in a Joint Venture. A Bidder who submits or participates in more than one bid will cause all the proposals with the Bidder's participation to be disqualified. This shall be without prejudice to any applicable criminal, civil and administrative penalties that may be imposed upon the persons and entities concerned.

12. Bid Prices

- 12.1. The Bidder shall complete the appropriate Schedule of Prices included herein, stating the unit prices, total price per item, the total amount and the expected countries of origin of the Goods to be supplied;
- 12.2. The Bidder shall fill in rates and prices for all items of the Goods described in the Schedule of Prices. Bids not addressing or providing all of the required items in the Bidding Documents including, where applicable, Schedule of Prices, shall be considered non-responsive and, thus, automatically disqualified. In this regard, where a required item is provided, but no price is indicated, the same shall be considered as non-responsive, but specifying a zero (0) or a dash (-) for the said item would mean that it is being offered for free;
- 12.3. Prices indicated on the Price Schedule shall be quoted at DDP price – Addis Ababa, Ethiopia.
- 12.4. Prices indicated on the Price Schedule shall be entered separately in the following manner:
- (a) For Goods offered from within Ethiopia:**
- (i) The price of the Goods quoted shall be the EXW;
 - (ii) The cost of all customs duties and sales and other taxes already paid or payable;
 - (iii) The cost of transportation, insurance, and other costs incidental to delivery of the Goods to their final destination; and
 - (iv) The price of other (incidental) services, if any, listed in the **BDS**.
- (b) For Goods offered from abroad:**
- (i) Unless otherwise stated in the **BDS**, the price of the Goods shall be quoted DDP with the place of destination in Ethiopia as specified in the **BDS**. In quoting the price, the Bidder shall be free to use transportation through carriers registered in any eligible country. Similarly, the Bidder may obtain insurance services from any eligible source country.
 - (ii) The price of other (incidental) services, if any, listed in the **BDS**.
- (c) For Services, based on the form which may be prescribed by the Procuring Entity, in accordance with existing laws, rules and regulation**

13. Bid Currency

Prices shall be quoted in the following currencies:

(a) For Goods that the Bidder will supply from within Ethiopia, the prices shall be quoted in Birr.

(b) For Goods that the Bidder will supply from outside of Ethiopia, the prices may be quoted in the currency (ices) stated in the **BDS**. However, for purposes of bid evaluation, bids denominated in foreign currencies shall be converted to Birr based on the exchange rate as published on the day of the bid opening.

© Unless otherwise specified in the **BDS**, payment of the contract price shall be made in Birr.

14. Bid Validity

14.1. Bids shall remain valid for the period specified in the **BDS** which shall not exceed one hundred twenty (90) calendar days from the date of the opening of bids.

14.2. In exceptional circumstances, prior to the expiration of the bid validity period, Bidders may be requested to extend the period of validity of their bids. The request and the responses shall be made in writing. The bid security described in ITB Clause 15 should also be extended corresponding to the extension of the bid validity period at the least. A Bidder may refuse the request without forfeiting its bid security, but his bid shall no longer be considered for further evaluation and award. A Bidder granting the request shall not be required or permitted to modify its bid.

15. Bid Security

15.1. The Bidder shall submit a Bid Security Declaration or any form of Bid Security in the amount stated in the **BDS**;

The Bid Securing Declaration mentioned above is an undertaking which states, among others, that the Bidder shall enter into contract with NCSC and furnish the performance security required under ITB Clause 30.2, within five (5) calendar days from receipt of the Notice of Award, and commits to pay the corresponding amount as fine,

15.2. The bid security should be valid for the period specified in the **BDS**. Any bid not accompanied by an acceptable bid security shall be rejected as non-responsive;

15.3. No bid securities shall be returned to Bidders after the opening of bids and before contract signing, except to those that failed or declared as post disqualified, upon submission of a written waiver of their right to file a request for reconsideration and/or protest, or upon the lapse of the reglementary period to file a request for reconsideration or protest. Without prejudice on its forfeiture, bid securities shall be returned only after the Bidder with the Lowest Calculated Responsive Bid (LCRB) has signed the contract and furnished the performance security, but in no case later than the expiration of the bid security validity period indicated in ITB Clause 14.1.

15.4. Upon signing and execution of the contract pursuant to ITB Clause 29, and the posting of the performance security pursuant to ITB Clause 30, the successful Bidder's bid security will be discharged, but in no case later than the bid security validity period as indicated in the ITB Clause 15.2

15.5. The bid security may be forfeited:

(a) If a Bidder:

- (i) withdraws its bid during the period of bid validity specified in ITB Clause 14;
- (ii) Does not accept the correction of errors pursuant to ITB Clause 25.3(b);
- (iii) Has a finding against the veracity of any of the documents submitted as stated in ITB Clause 26.2;
- (iv) submits eligibility requirements containing false information or falsified documents;
- (v) Submits bids that contain false information or falsified documents, or the concealment of such information in the bids in order to influence the outcome of eligibility screening or any other stage of the public bidding;
- (vi) Allows the use of one's name, or using the name of another for purposes of bidding;
- (vii) Withdraws a bid, or refuses to accept an award, or enter into contract without justifiable cause, after the Bidder had been adjudged as having submitted the LCRB;
- (viii) Refuses or fails to post the required performance security within the prescribed time;
- (ix) Refuses to clarify or validate in writing its bid during post qualification within a period of seven (7) calendar days from receipt of the request for clarification;
- (x) Made any documented attempt to unduly influence the outcome of the bidding in his favor;
- (xi) Potential joint venture partner fails to enter into the joint venture after the bid is declared successful; or

(b) If the successful Bidder:

- (i) Fails to sign the contract in accordance with ITB Clause 29; or
- (ii) Fails to furnish performance security in accordance with ITB Clause 30.

16. Format and Signing of Bids

16.1. Bidders shall submit their bids through their duly authorized representative using the appropriate forms provided in Section VIII. Bidding Forms on or before the deadline specified in the ITB Clauses 18 in two (2) separate sealed bid envelopes, and which shall be submitted simultaneously. The first shall contain the technical component of the bid, including the eligibility requirements under ITB Clause 9.1, and the second shall contain the financial component of the bid. This shall also be observed for each lot in the case of lot procurement.

16.2. Forms as mentioned in ITB Clause 16.1 must be completed without any alterations to their format, and no substitute form shall be accepted. All blank spaces shall be filled in with the information requested.

16.3. The Bidder shall prepare and submit an original of the first and second envelopes as described in ITB Clauses 9 and 10.

16.4. Each and every page of the Bid Form, including the Schedule of Prices, under Section VIII hereof, shall be signed by the duly authorized representative/s of the Bidder. Failure to do so shall be a ground for

the rejection of the bid.

16.5. Any interlineations, erasures, or overwriting shall be valid only if they are signed or initialed by the duly authorized representative/s of the Bidder.

17. Sealing and Marking of Bids

17.1. Bidders shall enclose their original eligibility and technical documents described in ITB Clause 9 in one sealed envelope marked "ORIGINAL - TECHNICAL COMPONENT", and the original of their financial component in another sealed envelope marked "ORIGINAL - FINANCIAL COMPONENT", sealing them all in an outer envelope marked "ORIGINAL BID".

17.2. The Bid shall be typed or written in ink and shall be signed by the Bidder or its duly authorized representative/s.

17.3 All envelopes shall:

- (a) Contain the name of the contract to be bid in capital letters;
- (b) Bear the name and address of the Bidder in capital letters;
- (c) Be addressed to NCSC's address in accordance with ITB Clause 2.1;
- (d) Bear the specific identification of this bidding process indicated in the **BDS &**
- (e) Bear a warning "DO NOT OPEN BEFORE..." the date and time for the opening of bids, in accordance with ITB Clause 21.

17.4. Bid envelopes that are not properly sealed and marked, as required in the bidding documents, shall not be rejected, but the Bidder or its duly authorized representative shall acknowledge such condition of the bid as submitted. The Procuring Entity shall assume no responsibility for the misplacement of the contents of the improperly sealed or marked bid, or for its premature opening.

D. Submission and Opening of Bids

18. Deadline for Submission of Bids

Bids must be submitted at the address and on or before the date and time indicated in the **BDS**;

19. Late Bids

Any bid submitted after the deadline for submission and receipt of bids prescribed, pursuant to ITB Clause 18, shall be declared "Late" and shall not be accepted. The Tender Committee shall record in the minutes of bid submission and opening, the Bidder's name, its representative and the time the late bid was submitted.

20. Modification and Withdrawal of Bids

20.1. The Bidder may modify its bid after it has been submitted; provided that the modification is received prior to the deadline prescribed for submission and receipt of bids. The Bidder shall not be allowed

to retrieve its original bid, but shall be allowed to submit another bid equally sealed and properly identified in accordance with ITB Clause 17, linked to its original bid marked as “TECHNICAL MODIFICATION” or “FINANCIAL MODIFICATION” and stamped “received”. Bid Modifications received after the applicable deadline shall not be considered and shall be returned to the Bidder unopened.

20.2 A Bidder may, through a Letter of Withdrawal, withdraw its bid after it has been submitted, for valid and justifiable reason; provided that the Letter of Withdrawal is received prior to the deadline prescribed for submission and receipt of bids. The Letter of Withdrawal must be executed by the duly authorized representative of the Bidder identified in the Sworn Statement, a copy of which should be attached to the letter.

20.3. Bids requested to be withdrawn in accordance with ITB Clause 20.1 shall be returned unopened to the Bidders. A Bidder, who has acquired the bidding documents, may also express its intention not to participate in the bidding through a letter which should reach and be stamped by the procuring entity before the deadline for submission and receipt of bids. A Bidder that withdraws its bid shall not be permitted to submit another bid, directly or indirectly, for the same contract.

20.4. No bid may be modified after the deadline for submission of bids. No bid may be withdrawn in the interval between the deadline for submission of bids and the expiration of the period of bid validity specified by the Bidder on the Financial Bid Form. Withdrawal of a bid during this interval shall result in the forfeiture of the Bidder’s bid security, pursuant to ITB Clause 15.5, and the imposition of administrative, civil and criminal sanctions,

21. Opening and Preliminary Examination of Bids

21.1. Bids shall be opened in public, immediately after the deadline for the submission and receipt of bids, as specified in the **BDS**. In case the Bids cannot be opened as scheduled due to justifiable reasons, the committee shall take custody of the Bids submitted and reschedule the opening of Bids on the next working day or at the soonest possible time through the issuance of a Notice of Postponement to be posted in the official website of NCSC.

21.2. Unless otherwise specified in the **BDS**, the tender committee shall open the first bid envelope and determine each Bidder’s compliance with the documents prescribed in ITB Clause 9, using a non-discretionary “pass/fail” criterion. If a Bidder submits the required document, it shall be rated “passed” for that particular requirement. In this regard, bids that fail to include any requirement or are incomplete shall be considered as “failed”.

21.3. After determining compliance with the requirements in the first envelope, the tender committee shall forthwith open the second bid envelope of each remaining eligible bidder whose first bid envelope was rated “passed”. The second envelope of each complying bidder shall be opened within the same day. In case one or more of the requirements in the second envelope of a particular bid is missing, incomplete or insufficient, the Committee shall rate the bid concerned as “failed”. Only bids that are determined to contain all the bid requirements for both components shall be rated “passed” and

shall immediately be considered for evaluation and comparison.

- 21.4. Letters of Withdrawal shall be read out and recorded during bid opening, and the envelope containing the corresponding withdrawn bid shall be returned to the Bidder unopened.
- 21.5. All members of the tender Committee, who are present during bid opening, shall initial every page of the original copies of all bids received and opened.
- 21.6. The Tender Committee shall prepare the minutes of the proceedings of the bid opening that shall include, as a minimum: (a) names of Bidders, their bid price (per lot, if applicable, and/or including discount, if any), bid security, findings of preliminary examination, and whether there is a withdrawal or modification; and (b) attendance sheet. The committee members shall sign the abstract of bids as read.
- 21.7 The bidders or their duly authorized representatives may attend the opening of bids. The committee shall ensure the integrity, security, and confidentiality of all submitted bids.
- 21.8 To ensure transparency and accurate representation of the bid submission, the Committee Secretariat shall notify in writing all bidders whose bids it has received through its NCSC's-registered physical address or official e-mail address. The notice shall be issued within seven (7) calendar days from the date of the bid opening.

E. Evaluation and Comparison of Bids

22. Process to be Confidential

- 22.1. Members of the tender committee, including its staff and personnel, as well as its Secretariat, are prohibited from making or accepting any kind of communication with any bidder regarding the evaluation of their bids until the issuance of the **Notice of Award**, unless otherwise allowed in the case of ITB Clause 23.
- 22.2. Any effort by a bidder to influence the Procuring Entity in the Procuring Entity's decision in respect of bid evaluation, bid comparison or contract award will result in the rejection of the Bidder's bid.

23. Clarification of Bids

To assist in the evaluation, comparison, and post-qualification of the bids, NCSC may ask in writing any Bidder for a clarification of its bid. All responses to requests for clarification shall be in writing. Any clarification submitted by a Bidder in respect to its bid and that is not in response to a request by the NCSC shall not be considered.

24. Domestic Preference

- 24.1. Unless otherwise stated in the **BDS**, the Procuring Entity will grant a margin of preference for the purpose of comparison of bids in accordance with the following:
 - (a) The preference shall be applied when the lowest Foreign Bid is lower than the lowest bid offered by a Domestic Bidder.

- (b) For evaluation purposes, the lowest Foreign Bid shall be increased by fifteen percent (15%).
- (c) In the event that the lowest bid offered by a Domestic Bidder does not exceed the lowest Foreign Bid as increased, then NCSC shall award the contract to the Domestic Bidder at the amount of the lowest Foreign Bid.
- (d) If the Domestic Bidder refuses to accept the award of contract at the amount of the Foreign Bid within two (2) calendar days from receipt of written advice from the tender committee, NCSC shall award to the bidder offering the Foreign Bid, subject to post-qualification and submission of all the documentary requirements under these Bidding Documents.

25. Detailed Evaluation and Comparison of Bids

- 25.1. NCSC will undertake the detailed evaluation and comparison of bids which have passed the opening and preliminary examination of bids, pursuant to ITB Clause 21, in order to determine the Lowest Calculated Bid.
- 25.2. The Lowest Calculated Bid shall be determined in two steps:
 - (a) The detailed evaluation of the financial component of the bids, to establish the correct calculated prices of the bids; and
 - (b) The ranking of the total bid prices as so calculated from the lowest to the highest. The bid with the lowest price shall be identified as the Lowest Calculated Bid.
- 25.3. The tender evaluation committee shall immediately conduct a detailed evaluation of all bids rated "passed," using non-discretionary pass/fail criteria.

The Committee shall consider the following in the evaluation of bids:

 - (a) **Completeness of the bid.** Bids not addressing or providing all of the required items in the Schedule of Requirements including, where applicable, Schedule of Prices, shall be considered non-responsive and, thus, automatically disqualified. In this regard, where a required item is provided, but no price is indicated, the same shall be considered as non-responsive, but specifying a zero (0) or a dash (-) for the said item would mean that it is being offered for free to the Procuring Entity;
 - (b) **Arithmetical corrections.** Consider computational errors and omissions to enable proper comparison of all eligible bids. It may also consider bid modifications. Any adjustment shall be calculated in monetary terms to determine the calculated prices.
- 25.4. Based on the detailed pre-evaluation of bids, those that comply with the requirements shall be considered for evaluation.
- 25.5. bidders shall be ranked in the ascending order of their total calculated bid prices, as evaluated and corrected for computational errors, discounts and other modifications, to identify the Lowest Calculated Bid.
- 25.6. Evaluation of bids shall be based on the bid price quoted in the Bid Form, which includes the Schedule of Prices.
- 25.7. Bids shall be evaluated on an equal footing to ensure fair competition. For this purpose, all bidders

shall be required to include in their bids the cost of all taxes, such as, but not limited to, value added tax (VAT), income tax, local taxes, and other fiscal levies and duties which shall be itemized in the bid form and reflected in the detailed estimates. Such bids, including said taxes, shall be the basis for bid evaluation and comparison.

26. Post-Qualification

- 26.1. NCSC shall determine to its satisfaction whether the Bidder that is evaluated as having submitted the Lowest Calculated Bid complies with and is responsive to all the requirements and conditions specified in ITB Clauses 2, 9, and 10.
- 26.2. Within a non-extendible period of five (5) calendar days from receipt by the bidder of the notice from the procurement Entity that it submitted the Lowest Calculated Bid, the Bidder shall submit audited financial statements of 2016/17 FY and other appropriate licenses and permits stated in **BDS**; Failure to submit any of the post-qualification requirements on time, or a finding against the veracity thereof, shall disqualify the bidder for award. Provided in the event that a finding against the veracity of any of the documents submitted is made, it shall cause the forfeiture of the bid security;
- 26.3. The determination shall be based upon an examination of the documentary evidence of the Bidder's qualifications submitted pursuant to ITB Clauses 9 and 10, as well as other information as the NCSC deems necessary and appropriate, using a non-discretionary "pass/fail" criterion, which shall be completed within a period of seven (7) calendar days.
- 26.4. If the Committee determines that the Bidder with the Lowest Calculated Bid passes all the criteria for post-qualification, it shall declare the said bid as the LCB, and the award of contract to the said Bidder, is offered, at its submitted price.
- 26.5. A negative determination shall result in rejection of the Bidder's Bid, in which event the Procuring Entity shall proceed to the next Lowest Calculated Bid with a fresh period to make a similar determination of that Bidder's capabilities to perform satisfactorily. If the second Bidder, however, fails the post qualification, the procedure for post qualification shall be repeated for the Bidder with the next Lowest Calculated Bid, and so on until the LCB is determined for recommendation for contract award.
- 26.6. Within a period not exceeding seven (7) calendar days from the determination by the committee of the LCB and the recommendation to award the contract, the CEO or his duly authorized representative shall approve or disapprove the said recommendation.
- 26.7. In the event of disapproval, which shall be based on valid, reasonable, and justifiable grounds, the CEO shall notify the tender committee and the Bidder in writing of such decision and the grounds for it. When applicable, the committee shall conduct a post qualification of the Bidder with the next Lowest Calculated Bid.

27. Reservation Clause

- 27.1. Notwithstanding the eligibility or post-qualification of a Bidder, NCSC reserves the right to review its

qualifications at any stage of the procurement process if it has reasonable grounds to believe that a misrepresentation has been made by the said Bidder, or that there has been a change in the Bidder's capability to undertake the project from the time it submitted its eligibility requirements. Should such review uncover any misrepresentation made in the eligibility and bidding requirements, statements or documents, or any changes in the situation of the Bidder which will affect its capability to undertake the project so that it fails the preset eligibility or bid evaluation criteria, NCSC shall consider the said Bidder as ineligible and shall disqualify it from submitting a bid or from obtaining an award or contract.

27.2. Based on the following grounds, NCSC reserves the right to reject any and all bids, declare a Failure of Bidding at any time prior to the contract award, or not to award the contract, without thereby incurring any liability, and make no assurance that a contract shall be entered into as a result of the bidding:

- (a) If there is evidence of collusion between bidder and employees of NCSC, or between the Committee and any of the Bidders, or if the collusion is between or among the bidders themselves, or between a Bidder and a third party, including any act which restricts, suppresses or nullifies competition;
- (b) If the tender committee is found to have failed in following the prescribed bidding procedures; or
- (c) For any justifiable and reasonable ground where the award of the contract will not redound to the benefit of NCSC as follows:
 - (i) If the physical and economic conditions have significantly changed so as to render the project no longer economically, financially or technically feasible as determined by the CEO;
 - (ii) If the project is no longer necessary as determined by the CEO; and
 - (iii) If the source of funds for the project has been withheld or reduced through no fault of the NCSC.

27.3. In addition, NCSC may likewise declare a failure of bidding when:

- (a) No bids are received;
- (b) All prospective Bidders are declared ineligible;
- (c) All bids fail to comply with all the bid requirements or fail post qualification; or
- (d) The bidder with the LCB refuses, without justifiable cause to accept the award of contract, and no award is made

F. Award of Contract

28. Contract Award

28.1. Subject to ITB Clause 26, the CEO or its duly authorized representative shall award the contract to the Bidder whose bid has been determined to be the LCB.

28.2. Prior to the expiration of the period of bid validity, NCSC shall notify the successful Bidder in writing that its bid has been accepted, through a Notice of Award duly received by the Bidder or its

representative personally or sent by registered mail or electronically, receipt of which must be confirmed in writing within two (2) days by the Bidder with the LCRB and submitted personally or sent by registered mail or electronically to NCSC.;

28.3. Notwithstanding the issuance of the Notice of Award, award of contract shall be subject to the following conditions:

- (a) Submission of the following documents within ten (10) calendar days from receipt of the Notice of Award:
 - (i) Valid Joint Venture Agreement, if applicable; or
- (b) Posting of the performance security in accordance with ITB Clause 30;
- (c) Signing of the contract as provided in ITB Clause 29; and

28.4. At the time of contract award, NCSC shall not increase or decrease the quantity of goods originally specified in Section VI. Schedule of Requirements.

29. Signing of the Contract

29.1. At the same time as NCSC notifies the successful Bidder that its bid has been accepted, it shall also send the Contract Form to the Bidder, which contract has been provided in the Bidding Documents, incorporating therein all agreements between the parties.

29.2. Within five (05) calendar days from receipt of the Notice of Award, the successful Bidder shall post the required performance security, sign and date the contract and return it to NCSC.

29.3. The Procuring Entity shall enter into contract with the successful Bidder within ten (10) calendar day period provided that all the documentary requirements are complied with.

29.4. The following documents shall form part of the contract:

- (a) Contract Agreement;
- (b) Bidding Documents;
- (c) Winning bidder's bid, including the Technical and Financial Proposals, and all other documents/statements submitted (e.g., bidder's response to request for clarifications on the bid), including corrections to the bid, if any, resulting from the Procuring Entity's bid evaluation;
- (d) Performance Security;
- (e) Notice of Award of Contract; and
- (f) Other contract documents that may be required by existing laws and/or specified in the **BDS**;

30. Performance Security

30.1. To guarantee the faithful performance by the winning Bidder of its obligations under the contract, it shall post a performance security within a maximum period of five (05) calendar days from the receipt of the Notice of Award from NCSC and in no case later than the signing of the contract.

30.2. The Performance Security shall be denominated in USD/Birr and posted in favor of the Procuring Entity in an amount equal to 10% of the total contract price.

30.3. Failure of the successful Bidder to comply with the above-mentioned requirement shall constitute sufficient ground for the annulment of the award and forfeiture of the bid security, in which event

NCSC shall have a fresh period to initiate and complete the post qualification of the second Lowest Calculated Bid. The procedure shall be repeated until the LCB is identified and selected for recommendation of contract award. However if no Bidder passed post-qualification, NCSC shall declare the bidding a failure and conduct a re-bidding with re-advertisement, if necessary.

31. Notice to Proceed

Within seven (7) calendar days from the date of approval of the contract, the Procuring Entity shall issue the Notice to Proceed (NTP) together with a copy or copies of the approved contract to the successful Bidder. All notices called for by the terms of the contract shall be effective only at the time of receipt thereof by the successful Bidder.

Section III: Bid Data Sheet (BDS)

ITB Clause	Particulars
1.2	<ul style="list-style-type: none"> • The Procuring Entity is National Cement Share Company (NCSC). • The name of the Contract is "Supply and Delivery of Two hundred Twenty (220) Units of Semi-trailer trucks." • The identification number of the Contract is NCSC- 0001/18
2.1	<ul style="list-style-type: none"> • National/International partnership, Private & Public Limited Companies, corporations;
4	No further instructions.
5	Subcontracting is not allowed
5.4	<ul style="list-style-type: none"> • The Bidder must have completed, within the period specified in the Invitation to Bid and ITB Clause 9.1(a)(iii), • The Bidder must have completed at least one similar Project, within three (3) Years prior to the deadline for the submission and receipt of bids; • Bidders shall include in their bids a photocopy of Single Largest Completed Contract or Purchase Order and the corresponding proof of completion, such as (i) Certificate of Final Acceptance from the Bidder's client; or (ii) Official Receipt issued by the Bidder. • Failure to submit a copy of Single Largest Completed Contract with proof of Completion or a failure against the veracity of such shall be a ground for disqualification of the Bidder for award and forfeiture of the bid security. For this purpose, similar contract shall refer to the supply and delivery of Semi-trailer trucks.
7.1	<p>The Procuring Entity's address is:</p> <ul style="list-style-type: none"> • Bid offer must be sent to our email address: foreign.purchase@nationalcementsc.com protected by multiple passwords of management members or may submit Addis Ababa office before the closing date. • National Cement Share Company Ethio-China Friendship Road Wello sefer KT-12 Building 1st floor Tel: Cell: +251930179609/+251930283483 E-mail: Abdurehman.seid@nationalcementsc.com
9.1(a)(iii)	The bidder's SLCC similar to the contract to be bid should have been completed within Three (3) Years prior to the deadline for the submission and receipt of bids.
10.b	No incidental services are required. 10(b) Not applicable. 16.1(b) The Bid prices for Goods supplied from outside of the Philippines shall be quoted in Philippine Pesos
12.4(a)iii	No incidental services are required. 12.4(a) Not applicable.
12.4(b)I & iii	No incidental services are required. 12.4(b)i Not applicable. 12.4(b)iii
13.(b)	The Bid prices for Goods supplied from outside of Ethiopia shall be quoted in USD
13.(c)	No additional requirements.
14.1	Bids will be valid until 90 calendar days from date of bid opening.

15.1	The bid security shall be in the form of bank draft/guarantee or irrevocable letter of credit in an amount of 2% of offered price of the bidder;
15.2	The bid security shall be valid until 90 calendar days from the date of bid opening.
16.3	Each Bidder shall submit only one (1) original of the first and second components of its bid.
17.3.d	The identification number of the Contract is NCSC- 0001/18
18	The deadline for submission of bids is on February11, 2018, 9:00am.
21.1	The date and time of bid opening is on February 14, 2018, 9:30am.
21.2	No further instructions.
24.1	No further instructions
26.2	Business License, VAT registration Certificate, PIN number.
25.3 (a)	Partial bid is not allowed. The goods are grouped in a single lot and the lot shall not be divided into sub-lots for the purpose of bidding, evaluation, and contract award.
29.4.f	No further instructions

Section IV: *General Conditions of Contract*

1. Definitions

1.1. In this Contract, the following terms shall be interpreted as indicated:

- (a) “The Contract” means the agreement entered into between the Procuring Entity and the Supplier, as recorded in the Contract Form signed by the parties, including all attachments and appendices thereto and all documents incorporated by reference therein.
- (b) “The Contract Price” means the price payable to the Supplier under the Contract for the full and proper performance of its contractual obligations.
- (c) “The Goods” means all of the supplies, equipment, machinery, spare parts, other materials and/or general support services which the Supplier is required to provide to the Procuring Entity under the Contract.
- (d) “The Services” means those services ancillary to the supply of the Goods, such as transportation and insurance, and any other incidental services, such as installation, commissioning, provision of technical assistance, training, and other such obligations of the Supplier covered under the Contract.
- (e) “GCC” mean the General Conditions of Contract contained in this Section.
- (f) “SCC” means the Special Conditions of Contract.
- (g) “The Procuring Entity” means the organization purchasing the Goods, as named in the **SCC**.
- (h) “The Procuring Entity’s country” is Ethiopia.
- (i) “The Supplier” means the individual contractor, manufacturer distributor, or firm

supplying/manufacturing the Goods and Services under this Contract and named in the **SCC**.

- (j) The “Funding Source” means the organization named in the **SCC**.
- (k) “The Project Site,” where applicable, means the place or places named in the **SCC**.
- (l) “Day” means calendar day.
- (m) The “Effective Date” of the contract will be the date of signing the contract; however the Supplier shall commence performance of its obligations only upon receipt of the Notice to Proceed and copy of the approved contract.
- (n) “Verified Report” refers to the report submitted by the Implementing Unit to the NCSC setting forth its findings as to the existence of grounds or causes for termination and explicitly stating its recommendation for the issuance of a Notice to Terminate.

2. Corrupt, Fraudulent, Collusive, and Coercive Practices

2.1. Unless otherwise provided in the **SCC**, the Procuring Entity as well as the bidders, contractors, or suppliers shall observe the highest standard of ethics during the procurement and execution of this Contract. In pursuance of this policy, the Procuring Entity:

(a) Defines, for the purposes of this provision, the terms set forth below as follows:

(i) **"corrupt practice"** means behavior on the part of officials in the public or private sectors by which they improperly and unlawfully enrich themselves, others, or induce others to do so, by misusing the position in which they are placed, and it includes the offering, giving, receiving, or soliciting of anything of value to influence the action of any such official in the procurement process or in contract execution; entering, on behalf of the Government, into any contract or transaction

manifestly and grossly disadvantageous to the same, whether or not the public officer profited or will profit thereby,

(ii) **"fraudulent practice"** means a misrepresentation of facts in order to influence a procurement process or the execution of a contract to the detriment of the Procuring Entity, and includes collusive practices among Bidders (prior to or after bid submission) designed to establish bid prices at artificial, noncompetitive levels and to deprive the Procuring Entity of the benefits of free and open competition.

(iii) **"Collusive practices"** means a scheme or arrangement between two or more Bidders, with or without the knowledge of the Procuring Entity, designed to establish bid prices at artificial, non-competitive levels.

(iv) **"coercive practices"** means harming or threatening to harm, directly or indirectly, persons, or their property to influence their participation in a procurement process, or affect the execution of a contract;

(v) **"Obstructive practice"** is:

(aa) deliberately destroying, falsifying, altering or concealing of evidence material to an administrative proceedings or investigation or making false statements to investigators in order to materially impede an

administrative proceedings or investigation of the Procuring Entity or any foreign government/foreign or international financing institution into allegations of a corrupt, fraudulent, coercive or collusive practice; and/or threatening, harassing or intimidating any party to prevent it from disclosing its knowledge of matters relevant to the administrative proceedings or investigation or from pursuing such proceedings or investigation; or

(bb) acts intended to materially impede the exercise of the inspection and audit rights of the Procuring Entity or any foreign government/foreign or international financing institution herein.

(b) Will reject a proposal for award if it determines that the Bidder recommended for award has engaged in any of the practices mentioned in this Clause for purposes of competing for the contract.

2.2. Further the Funding Source, Borrower or Procuring Entity, as appropriate, will seek to impose the maximum civil, administrative and/or criminal penalties available under the applicable law on individuals and organizations deemed to be involved with any of the practices mentioned in GCC Clause 2.1(a).

3. Inspection

The Supplier shall permit the procuring Entity to inspect and certify performance conformance prior to receipt of Goods;

4. Governing Law and Language

4.1. This Contract shall be interpreted in accordance with the laws of Ethiopia.

4.2. This Contract has been executed in the English language, which shall be the binding and controlling language for all matters relating to the meaning or interpretation of this Contract. All correspondence and other documents pertaining to this Contract exchanged by the parties shall be written in English.

5. Notices

5.1. Any notice, request, or consent required or permitted to be given or made pursuant to this Contract shall be in writing. Any such notice, request, or consent shall be deemed to have been given or made when received by the concerned party, either in person or through an authorized representative of the Party to whom the communication is addressed, or when sent by registered mail, telex, telegram, or facsimile to such Party at the address specified in the SCC, which shall be effective when delivered and duly received or on the notice's effective date, whichever is later.

5.2. A Party may change its address for notice hereunder by giving the other Party notice of such change pursuant to the provisions listed in the SCC for GCC Clause 5.1.

6. Scope of Contract

6.1. The Goods and Related Services to be provided shall be as specified in Section VI. Schedule of Requirements.

6.2. This Contract shall include all such items, although not specifically mentioned, that can be reasonably inferred as being required for its completion as if such items were expressly

mentioned herein. Any additional requirements for the completion of this Contract shall be provided in the SCC.

7. Subcontracting

- 7.1. Subcontracting of any portion of the Goods, if allowed in the BDS, does not relieve the Supplier of any liability or obligation under this Contract. The Supplier will be responsible for the acts, defaults, and negligence of any subcontractor, its agents, servants or workmen as fully as if these were the Supplier's own acts, defaults, or negligence, or those of its agents, servants or workmen.
- 7.2. If subcontracting is allowed, the Supplier may identify its subcontractor during contract implementation. Subcontractors disclosed and identified during the bidding may be changed during the implementation of this Contract. In either case, subcontractors must submit the documentary requirements under ITB Clause 12 and comply with the eligibility criteria specified in the BDS. In the event that any subcontractor is found by the Procuring Entity to be ineligible, the subcontracting of such portion of the Goods shall be disallowed.

8. Procuring Entity's Responsibilities

- 8.1. Whenever the performance of the obligations in this Contract requires that the Supplier obtain permits, approvals, import, and other licenses from local Public authorities, the Procuring Entity shall, if so needed by the Supplier, make its best effort to assist the Supplier in complying with such requirements in a timely and expeditious manner.
- 8.2. The Procuring Entity shall pay all costs involved in the performance of its responsibilities in accordance with GCC Clause 6.

9. Prices

- 9.1. For the given scope of work in this Contract as awarded, all bid prices are considered fixed prices, and therefore not subject to price escalation during contract implementation, except under extraordinary circumstances and upon
- 9.2. Prices charged by the Supplier for Goods delivered and/or services performed under this Contract shall not vary from the prices quoted by the Supplier in its bid, with the exception of any change in price resulting from a Change Order issued in accordance with GCC Clause 29.

10. Payment

- 10.1. Payments shall be made only upon a certification by the CEO of NCSC to the effect that the Goods have been rendered or delivered in accordance with the terms of this Contract and have been duly inspected and accepted. No payment shall be made for services not yet rendered or for supplies and materials not yet delivered under this Contract. Ten percent (10%) of the amount of each payment shall be retained by the Procuring Entity to cover the Supplier's warranty obligations under this Contract as described in GCC Clause 17.
- 10.2. The Supplier's request(s) for payment shall be made to the Procuring Entity in writing, accompanied by an invoice describing, as appropriate, the Goods delivered and/or Services performed, and by documents submitted pursuant to the SCC provision for GCC Clause 6.2, and upon fulfillment of

other obligations stipulated in this Contract.

10.3. Pursuant to GCC Clause 10.2, payments shall be made promptly by the Procuring Entity, but in no case later than sixty (60) days after submission of an invoice or claim by the Supplier. Payments shall be in accordance with the schedule stated in the SCC.

10.4. Unless otherwise provided in the SCC, the currency in which payment is made to the Supplier under this Contract shall be in Birr.

11. Advance Payment and Terms of Payment

11.1. Advance payment shall be made only after prior approval by the CEO of NCSC and shall not exceed fifteen percent (30%) of the Contract amount, unless otherwise directed by the CEO;

11.2. Unless otherwise indicated in the SCC, the terms of payment shall be as follows:

(a) On Contract Signature: Thirty Percent (30%) of the Contract Price shall be paid within fifteen (15) days from signing of the Contract and upon submission of a bank guarantee for the equivalent amount valid until the Goods are delivered and in the form provided in Section VIII. Bidding Forms.

(b) On Delivery: Sixty percent (60%) of the Contract Price shall be paid to the Supplier within sixty (60) days after the date of receipt of the Goods and upon submission of the documents (i) through (vi) specified in the SCC provision on Delivery and Documents.

(c) On Acceptance: The remaining ten percent (10%) of the Contract Price shall be paid to the Supplier within thirty (30) days after the date of submission of the acceptance and inspection certificate for the respective delivery issued by the Procuring Entity. In the event that no inspection or acceptance certificate is issued by the Procuring Entity's within forty five (45) days of the date shown on the delivery receipt, the Supplier shall have the right to claim payment of the remaining ten percent (10%) subject to the Procuring Entity's own verification of the reason(s) for the failure to issue documents (vii) and (viii) as described in the SCC provision on Delivery and Documents.

12. Taxes and Duties

The Supplier, whether local or foreign, shall be entirely responsible for all the necessary taxes, stamp duties, license fees, and other such levies imposed for the completion of this Contract.

13. Performance Security

13.1. Within five (5) calendar days from receipt of the Notice of Award from the Procuring Entity but in no case later than the signing of the contract by both parties, the successful Bidder shall furnish the performance security in any the forms prescribed in the ITB Clause 30.2.

13.2. The performance security posted in favor of the Procuring Entity shall be forfeited in the event it is established that the winning bidder is in default in any of its obligations under the contract.

13.3. The performance security shall remain valid until issuance by the Procuring Entity of the Certificate of Final Acceptance.

13.4. The performance security may be released by the Procuring Entity and returned to the Supplier after the issuance of the Certificate of Final Acceptance subject to the following conditions:

- (a) There are no pending claims against the Supplier or the surety company filed by the Procuring Entity;
- (b) Other terms specified in the SCC.

13.5. In case of a reduction of the contract value, the Procuring Entity shall allow a proportional reduction in the original performance security, provided that any such reduction is more than ten percent (10%) of the original performance security.

14. Use of Contract Documents and Information

14.1. The Supplier shall not, except for purposes of performing the obligations in this Contract, without the Procuring Entity's prior written consent, disclose this Contract, or any provision thereof, or any specification, plan, drawing, pattern, sample, or information furnished by or on behalf of the Procuring Entity. Any such disclosure shall be made in confidence and shall extend only as far as may be necessary for purposes of such performance.

14.2. Any document, other than this Contract itself, enumerated in GCC Clause 14.1 shall remain the property of the Procuring Entity and shall be returned (all copies) to the Procuring Entity on completion of the Supplier's performance under this Contract if so required by the Procuring Entity.

15. Standards

The Goods provided under this Contract shall conform to the standards mentioned in the Section VII. Technical Specifications; and, when no applicable standard is mentioned, to the authoritative standards appropriate to the Goods' country of origin. Such standards shall be the latest issued by the institution concerned.

16. Inspection and Tests

16.1. The Procuring Entity or its representative shall have the right to inspect and/or to test the Goods to confirm their conformity to the Contract specifications at no extra cost to the Procuring Entity. The SCC and Section VII. Technical Specifications shall specify what inspections and/or tests the Procuring Entity requires and where they are to be conducted. The Procuring Entity shall notify the Supplier in writing, in a timely manner, of the identity of any representatives retained for these purposes.

16.2. If applicable, the inspections and tests may be conducted on the premises of the Supplier or its subcontractor(s), at point of delivery, and/or at the goods' final destination. If conducted on the premises of the Supplier or its subcontractor(s), all reasonable facilities and assistance, including access to drawings and production data, shall be furnished to the inspectors at no charge to the Procuring Entity. The Supplier shall provide the Procuring Entity with results of such inspections and tests.

16.3. The Procuring Entity or its designated representative shall be entitled to attend the tests and/or inspections referred to in this Clause provided that the Procuring Entity shall bear all of its own costs and expenses incurred in connection with such attendance including, but not limited to, all traveling and board and lodging expenses.

16.4. The Procuring Entity may reject any Goods or any part thereof that fail to pass any test and/or inspection or do not conform to the specifications. The Supplier shall either rectify or replace such rejected Goods or parts thereof or make alterations necessary to meet the specifications at no cost to

the Procuring Entity, and shall repeat the test and/or inspection, at no cost to the Procuring Entity, upon giving a notice pursuant to GCC Clause 5.

- 16.5. The Supplier agrees that neither the execution of a test and/or inspection of the Goods or any part thereof, nor the attendance by the Procuring Entity or its representative, shall release the Supplier from any warranties or other obligations under this Contract.

17. Warranty

- 17.1. The Supplier warrants that the Goods supplied under the Contract are new, unused, of the most recent or current models, and that they incorporate all recent improvements in design and materials, except when the technical specifications required by the Procuring Entity provides otherwise.
- 17.2. The Supplier further warrants that all Goods supplied under this Contract shall have no defect, arising from design, materials, or workmanship or from any act or omission of the Supplier that may develop under normal use of the supplied Goods in the conditions prevailing in the country of final destination.
- 17.3. In order to assure that manufacturing defects shall be corrected by the Supplier, a warranty shall be required from the Supplier for a period of two years or 300,000 km whichever comes first. The obligation for the warranty shall be covered, in a special bank guarantee equivalent to at least one percent (1%) of the total Contract Price .The said amounts shall only be released after the lapse of the warranty period specified in the SCC; provided, however, that the Supplies delivered are free from patent and latent defects and all the conditions imposed under this Contract have been fully met.
- 17.4. The Procuring Entity shall promptly notify the Supplier in writing of any claims arising under this warranty. Upon receipt of such notice, the Supplier shall, within the period specified in the SCC and with all reasonable speed, repair or replace the defective Goods or parts thereof, without cost to the Procuring Entity.
- 17.5. If the Supplier, having been notified, fails to remedy the defect(s) within the period specified in GCC Clause 17.4, the Procuring Entity may proceed to take such remedial action as may be necessary, at the Supplier's risk and expense and without prejudice to any other rights which the Procuring Entity may have against the Supplier under the Contract and under the applicable law.

18. Delays in the Supplier's Performance

- 18.1. Delivery of the Goods and/or performance of Services shall be made by the Supplier in accordance with the time schedule prescribed by the Procuring Entity in Section VI. Schedule of Requirements.
- 18.2. If at any time during the performance of this Contract, the Supplier or its Subcontractor(s) should encounter conditions impeding timely delivery of the Goods and/or performance of Services, the Supplier shall promptly notify the Procuring Entity in writing of the fact of the delay, its likely duration and its cause(s). As soon as practicable after receipt of the Supplier's notice, and upon causes provided for under GCC Clause 22, the Procuring Entity shall evaluate the situation and may extend the Supplier's time for performance, in which case the extension shall be ratified by the

parties by amendment of Contract.

18.3. Except as provided under GCC Clause 22, a delay by the Supplier in the performance of its obligations shall render the Supplier liable to the imposition of liquidated damages pursuant to GCC Clause 19, unless an extension of time is agreed upon pursuant to GCC Clause 29 without the application of liquidated damages.

19. Liquidated Damages

Subject to GCC Clauses 18 and 22, if the Supplier fails to satisfactorily deliver any or all of the Goods and/or to perform the Services within the period(s) specified in this Contract inclusive of duly granted time extensions if any, the Procuring Entity shall, without prejudice to its other remedies under this Contract and under the applicable law, deduct from the Contract Price, as liquidated damages, the applicable rate of one percent of the cost of the unperformed portion for every day of delay until actual delivery or performance. The maximum deduction shall be ten percent (10%) of the amount of contract. Once the maximum is reached, the Procuring Entity may rescind or terminate the Contract pursuant to GCC Clause 23, without prejudice to other courses of action and remedies open to it.

20. Settlement of Disputes

20.1. If any dispute or difference of any kind whatsoever shall arise between the Procuring Entity and the Supplier in connection with or arising out of this Contract, the parties shall make every effort to resolve amicably such dispute or difference by mutual consultation.

20.2. If after thirty (30) days, the parties have failed to resolve their dispute or difference by such mutual consultation, then either the Procuring Entity or the Supplier may give notice to the other party of its intention to commence arbitration, as hereinafter provided, as to the matter in dispute, and no arbitration in respect of this matter may be commenced unless such notice is given.

20.3. Any dispute or difference in respect of which a notice of intention to commence arbitration has been given in accordance with this Clause shall be settled by arbitration. Arbitration may be commenced prior to or after delivery of the Goods under this Contract. Place of provisions and Arbitration shall be in Diredawa and the Ethiopian arbitration provision respectively;

20.4. In the case of a dispute between the Procuring Entity and the Supplier, the dispute shall be resolved in accordance with relevant provisions of the law of Ethiopia;

20.5. Notwithstanding any reference to arbitration herein, the parties shall continue to perform their respective obligations under the Contract unless they otherwise agree; and the Procuring Entity shall pay the Supplier any monies due the Supplier.

21. Liability of the Supplier

21.1. The Supplier's liability under this Contract shall be as provided by the laws of Ethiopia, subject to additional provisions, if any, set forth in the SCC.

21.2. Except in cases of criminal negligence or willful misconduct, and in the case of infringement of patent rights, if applicable, the aggregate liability of the Supplier to the Procuring Entity shall not exceed the total Contract Price, provided that this limitation shall not apply to the cost of repairing or replacing defective equipment.

22. Force Majeure

- 22.1. The Supplier shall not be liable for forfeiture of its performance security, liquidated damages, or termination for default if and to the extent that the Supplier's delay in performance or other failure to perform its obligations under the Contract is the result of a force majeure.
- 22.2. For purposes of this Contract the terms "force majeure" and "fortuitous event" may be used interchangeably. In this regard, a fortuitous event or force majeure shall be interpreted to mean an event which the Supplier could not have foreseen, or which though foreseen, was inevitable. It shall not include ordinary unfavorable weather conditions; and any other cause the effects of which could have been avoided with the exercise of reasonable diligence by the Supplier. Such events may include, but not limited to, acts of the Procuring Entity in its sovereign capacity, wars or revolutions, fires, floods, epidemics, quarantine restrictions, and freight embargoes.
- 22.3. If a force majeure situation arises, the Supplier shall promptly notify the Procuring Entity in writing of such condition and the cause thereof. Unless otherwise directed by the Procuring Entity in writing, the Supplier shall continue to perform its obligations under the Contract as far as is reasonably practical, and shall seek all reasonable alternative means for performance not prevented by the force majeure.

23. Termination for Default

- 23.1. The Procuring Entity shall terminate this Contract for default when any of the following conditions attends its implementation:
- (a) Outside of force majeure, the Supplier fails to deliver or perform any or all of the Goods within the period(s) specified in the contract, or within any extension thereof granted by the Procuring Entity pursuant to a request made by the Supplier prior to the delay, and such failure amounts to at least ten percent (10%) of the contract price;
 - (b) As a result of force majeure, the Supplier is unable to deliver or perform any or all of the Goods, amounting to at least ten percent (10%) of the contract price, for a period of not less than sixty (60) calendar days after receipt of the notice from the Procuring Entity stating that the circumstance of force majeure is deemed to have ceased; or
 - (c) The Supplier fails to perform any other obligation under the Contract.
- 23.2. In the event the Procuring Entity terminates this Contract in whole or in part, for any of the reasons provided under GCC Clauses 23 to 26, the Procuring Entity may procure, upon such terms and in such manner as it deems appropriate, Goods or Services similar to those undelivered, and the Supplier shall be liable to the Procuring Entity for any excess costs for such similar Goods or Services. However, the Supplier shall continue performance of this Contract to the extent not terminated.
- 23.3. In case the delay in the delivery of the Goods and/or performance of the Services exceeds a time duration equivalent to ten percent (10%) of the specified contract time plus any time extension duly granted to the Supplier, the Procuring Entity may terminate this Contract, forfeit the Supplier's performance security and award the same to a qualified Supplier.

24. Termination for Insolvency

The Procuring Entity shall terminate this Contract if the Supplier is declared bankrupt or insolvent as determined with finality by a court of competent jurisdiction. In this event, termination will be without compensation to the Supplier, provided that such termination will not prejudice or affect any right of action or remedy which has accrued or will accrue thereafter to the Procuring Entity and/or the Supplier.

25. Termination for Convenience

25.1. The Procuring Entity may terminate this Contract, in whole or in part, at any time for its convenience. NCSC may terminate a contract for the convenience of the company if it has determined the existence of conditions that make Project Implementation economically, financially or technically impractical and/or unnecessary, such as, but not limited to, fortuitous event(s) or changes in law and national government policies.

25.2. The Goods that have been delivered and/or performed or are ready for delivery or performance within thirty (30) calendar days after the Supplier's receipt of Notice to Terminate shall be accepted by the Procuring Entity at the contract terms and prices. For Goods not yet performed and/or ready for delivery, the Procuring Entity may elect:

(a) to have any portion delivered and/or performed and paid at the contract terms and prices; and/or

(b) to cancel the remainder and pay to the Supplier an agreed amount for partially completed and/or performed goods and for materials and parts previously procured by the Supplier.

25.3. If the Supplier suffers loss in its initial performance of the terminated contract, such as purchase of raw materials for goods specially manufactured for the Procuring Entity which cannot be sold in open market, it shall be allowed to recover partially from this Contract, on a quantum meruit basis. Before recovery may be made, the fact of loss must be established under oath by the Supplier to the satisfaction of the Procuring Entity before recovery may be made.

26. Termination for Unlawful Acts

26.1. The Procuring Entity may terminate this Contract in case it is determined that the Supplier has engaged, before or during the implementation of this Contract, in unlawful deeds and behaviors relative to contract acquisition and implementation. Unlawful acts include, but are not limited to, the following:

(a) Corrupt, fraudulent, and coercive practices;

(b) Drawing up or using forged documents;

(c) Using adulterated materials, means or methods, or engaging in production contrary to rules of science or the trade; and

(d) Any other act analogous to the foregoing.

27. Procedures for Termination of Contracts

27.1. The following provisions shall govern the procedures for termination of this Contract:

(a) Upon receipt of a written report of acts or causes which may constitute ground(s) for termination

as aforementioned, or upon its own initiative, the Implementing Unit shall, within a period of seven (7) calendar days, verify the existence of such ground(s) and cause the execution of a Verified Report, with all relevant evidence attached;

- (b) Upon recommendation by the Implementing Unit, the NCSC shall terminate this Contract only by a written notice to the Supplier conveying the termination of this Contract. The notice shall state:
 - (i) That this Contract is being terminated for any of the ground(s) afore-mentioned, and a statement of the acts that constitute the ground(s) constituting the same;
 - (ii) The extent of termination, whether in whole or in part;
 - (iii) An instruction to the Supplier to show cause as to why this Contract should not be terminated; and
 - (iv) Special instructions of the Procuring Entity, if any.
- (c) The Notice to Terminate shall be accompanied by a copy of the Verified Report;
- (d) Within a period of seven (7) calendar days from receipt of the Notice of Termination, the Supplier shall submit to NCSC a verified position paper stating why this Contract should not be terminated. If the Supplier fails to show cause after the lapse of the seven (7) day period, either by inaction or by default, NCSC shall issue an order terminating this Contract;
- (e) The Procuring Entity may, at any time before receipt of the Supplier's verified position paper described in item (d) above withdraw the Notice to Terminate if it is determined that certain items or works subject of the notice had been completed, delivered, or performed before the Supplier's receipt of the notice;
- (f) Within a non-extendible period of ten (10) calendar days from receipt of the verified position paper, NCSC shall decide whether or not to terminate this Contract. It shall serve a written notice to the Supplier of its decision and, unless otherwise provided, this Contract is deemed terminated from receipt of the Supplier of the notice of decision. The termination shall only be based on the ground(s) stated in the Notice to Terminate;
- (g) The NCSC may create a Contract Termination Review Committee (CTRC) to assist him in the discharge of this function. All decisions recommended by the CTRC shall be subject to the approval of the NCSC; and
- (h) The Supplier must serve a written notice to the Procuring Entity of its intention to terminate the contract at least thirty (30) calendar days before its intended termination. The Contract is deemed terminated if it is not resumed in thirty (30) calendar days after the receipt of such notice by the Procuring Entity.

28. Assignment of Rights

The Supplier shall not assign his rights or obligations under this Contract, in whole or in part, except with the Procuring Entity's prior written consent.

29. Contract Amendment

Subject to applicable laws, no variation in or modification of the terms of this Contract shall be made except by written amendment signed by the parties.

30. Application

These General Conditions shall apply to the extent that they are not superseded by provisions of other parts of this Contract.

Section V: Special Conditions of Contract

GCC Clause	Particulars
1.1(g)	The Procuring Entity is National Cement Share Company.
1.1(i)	The Supplier is [to be inserted at the time of contract award].
1.1(j)	The approved budget of the company for FY 2016/17
1.1(k)	The Project sites are defined in Section VI. Schedule of Requirements
2.1	No further instructions.
5.1	foreign.purchase@nationalcementsc.com protected by multiple passwords of management members or may be submitted to the Addis Ababa Liaison office The Supplier's address for Notices is: _____
6.2	No additional provision.
10.4	Not applicable.
10.5	Not applicable
11.3	Maintain the GCC Clause.
13.4(c)	No further instructions.
16.1	The Goods delivered are accepted by NCSC as to quantity only. However, inspection as to the Goods' compliance with Section VII. Technical Specifications, and its order and condition, will be done in the presence of the representatives of both the Supplier and the NCSC upon prior due notice, written or verbal, to the authorized representative of the Supplier. The inspection will push through as scheduled even in the absence of the Supplier's representative, if the latter was duly notified. In which case, the results of the inspection conducted by the NCSC shall be final and binding upon the Supplier.
17.3	To assure that manufacturing defects shall be corrected by the Supplier, a warranty shall be required from the Supplier for a minimum period of one (1) year, after acceptance of the delivery by the Procuring Entity. The Supplier's two-year warranty shall be covered by, a special bank guarantee equivalent to at least ten percent (10%) of the Contract Price. The said amounts shall only be released after the lapse of the one (1) year warranty period, provided, however, that the Supplies delivered are free from patent and latent defects and all the conditions imposed under this Contract have been fully met.
17.4	The period of correction of defects shall be made within seven (7) calendar days from either verbal or written notification.
21.1	No additional provision.

Section VI: Schedule of Requirements

The delivery schedule expressed as weeks/months stipulates hereafter a delivery date which is the date of delivery to the procuring entity.

Description	Quantity	Delivered, Weeks/Months
SEMI TRAILER TRUCK	220	Not later than 90 calendar days upon receipt of the Notice to Proceed
CONSUMEBELE SPARE & FIELD KITS FOR TRUCKS	43 line items listed under B. Technical Specification	Not later than 90 calendar days upon receipt of the Notice to Proceed

I hereby certify to comply and deliver all the above requirements.

Name of
Company/Bidder

Signature over Printed Name of
Authorized Representative

Date

Section VII: Technical Specifications

SN	Item Specification	Statement of Compliance
		Bidders must state here either "Comply" or "Not Comply" against each of the individual parameters of each Specification stating the corresponding performance parameter of the equipment offered. Statements of "Comply" or "Not Comply" must be supported by evidence in a Bidders Bid and cross-referenced to that evidence. Evidence shall be in the form of manufacturer's un-amended sales literature, unconditional statements of specification and compliance issued by the manufacturer, samples, independent test data etc., as appropriate. A statement that is not supported by evidence or is subsequently found to be contradicted by the evidence presented will render the Bid under evaluation liable for rejection. A statement either in the Bidders statement of compliance or the supporting evidence that is found to be false either during Bid evaluation, post-qualification or the execution of the Contract may be regarded as fraudulent and render the Bidder or supplier liable for prosecution subject to the provisions of ITB Clause 3.1(a)(ii) and/or GCC Clause 2.1(a)(ii)
	Truck Chassis Cab, 6X4 Specifications	
1	FUNDAMENTAL REQUIREMENTS	
1.1	Scope	It describe semi-trailer truck 6x4 chassis cab suitable for towing a 3-axle semi-trailer and that have a capacity to carry 40 ton. The truck-semi-trailer combination shall be of not less than 60 metric tons gross combination weight. The chassis cab shall have the following basic parameters.

	• Gross vehicle semi-trailer weight	not less than 60 metric tons
	• Pay load	40 metric tons
	• Truck Wheel Base	4000 mm
	• Truck width	2.50 meter
	• Drive type	6x4,tandem rear axle drive
	• Power plant	water cooled, Turbo ,inter-cooled, diesel Engine
1.2	Service Requirements:	The chassis cab described herein shall be used for transporting general cargo, including heavy concentrated loads, on and off (extremely rough) roads in Ethiopia and neighboring countries where:
		• Temperature ranges from 0 ^o c-50 ^o c
		• Climate varies from humid tropics to arid deserts
		• Altitude
		• Varies from sea level up- to an average of 2500m high.
		All mountings, supports, bolts and suspensions and all other components shall be of the heavy-duty design to resist the shocks and vibrations induced by the extremely rough and poorly maintained paved roads.
1.3	Warranty (Fundamental):	The manufacturer shall guarantee that all parts and materials used for the construction of the vehicle be new, of high quality and good workmanship. The manufacturer shall undertake to replace or repair any part or component of the vehicle that fails or breaks due to defective material or workmanship while the vehicle is operated as per the service requirements for a minimum period of two years or 300,000 km from the date the truck is put in to operation. The cost of transporting, replacing/fitting, repairing and any incidental costs (labor + material cost), up to and where the vehicle is stranded shall be borne by the Seller.
1.4	Parts List:	Manufacturer's recommended fast moving spare parts list with price to a value of 3% of the vehicle shall be given as part of the offer. The list should include consumable spare parts and field kits enough for two year. (The minimum required, but not limited to, consumable spare parts and field kits is attached in separate sheet).
1.5	Field kit of spare parts:	Manufacturer's standard field kits shall be supplied with the vehicle. List of such parts with unitary and total price shall be given with the offer.
1.6	Run-in service:	The manufacturer or his delegate/dealer shall provide pre-delivery service, i.e.: washing, lubricating, inspecting and correction service before the truck is put into operation without any cost (labor + material) to the buyer at final destination.
2	ENGINE: 430 HP	
2.1	General Requirements:	The engine to be supplied shall perform smoothly and efficiently under the conditions described herein and shall develop the rated horsepower when operated with commercial diesel fuel available in the local market.
2.2	Engine Type (Fundamental):	The engine shall be four stroke cycle, water-cooled, turbo charged, inter-cooled, six cylinders, BOSCH high pressure common rail type

with replaceable cylinder sleeves (dry type).

2.3	Performance:	The engine shall be capable of sustained operation at 80 kilometers per hour with the unit fully loaded on a smooth, dry level road condition without any evidence of being overloaded. The engine shall be capable of operation under all conditions specified in the service requirements.
2.4	Horse power and Torque rating:	The engine shall deliver a power of 430 HP at a Governed R.P.M of not more than 2000, at sea level, with all required accessories. <ul style="list-style-type: none"> • Certified engine data which shall show net horsepower and torque performance curves both at sea level and at 2500 meters elevation. • Fuel consumption curve which shall be obtained when the unit is operated at the most economical speed, fully loaded to its gross combination weight (GCW) rating, on smooth level road, both at sea level and 2500 m elevation.
2.5	Lubrication System:	The manufacturer's current standard production fully forced feed type, gear driven engine lubrication system shall be accepted.
3	FUEL SYSTEM:	
3.1	Fuel Tanks:	The vehicle shall be equipped with two fuel tanks with a combined capacity of 600 liters minimum. Fuel tanks shall be mounted on each side of the chassis frame. Fuel shall be drawn to the fuel pump from each tank simultaneously. Fuel tanks shall be properly ventilated and shall incorporate baffled sump to collect water formed by condensation. Fuel tanks support brackets and retaining straps shall be of a heavy duty type to resist the extreme rough road vibrations. Fuel tank caps shall be lockable. (The fuel tank caps should only permits to enter fuel but not to draw out from it). Each tank shall have a cable support (covered with vinyl) mounted in such a way that it will share the weight of the tank when filled to capacity.
3.2	Filters:	Fuel filters shall be of the series coupled double stage type of adequate capacity and construction for the size and type of engine to be fitted and shall have a water separator device . The filters shall be located away from the ambient air stream preferable in the engine compartment. They shall be accessible for quick maintenance . Fuel filters shall be equipped with pre-filter and water drain valve.
4	COOLING SYSTEM:	
4.1	General Requirements:	The cooling system shall be of the closed, pressurized pump forced, water medium with ample capacity to permit continuous full load operation without boiling under the conditions specified in the service requirements herein.
4.2	Thermostat:	The cooling system shall be fitted with an efficient thermostat to ensure prompt (rapid) warming of the engine. The thermostat shall have minimum/maximum, opening/closing settings to meet operating conditions in Ethiopia.
4.3	Radiator:	The radiator shall be of extra heavy-duty type construction, with overflow tank protection. It shall be mounted in such a way as to withstand shocks & strains likely to be encountered under normal operating conditions throughout Ethiopia. The radiator shall have adequate capacity and flow area, plus 10 percent compensation for

		altitude and temperatures in Ethiopia.
4.4	Fan:	The cooling system shall have heavy duty, visco-static tropical type fan with shroud for the most efficient engine operation. Fan blades shall be made up of molded PVC . The fan must be belt drive.
4.5	Warning Device:	Within the driver's compartment, an audible and visual warning device shall be installed. The device shall activate when the engine cooling system temperature reaches the maximum temperature set by the engine manufacturer. The device shall remain on until the temperature has decreased to a safe operating range.
4.6	Air Intake System:	The Air intake system shall consist of a dry type, two-Stage, Double Element , heavy-duty air cleaner compatible with highly dusty operating conditions. A restriction gauge (low-pressure indicator) shall be placed on the air cleaning system, and shall be easily readable. An air intake at cab roof height is required. The air cleaner mounting shall be extra heavy duty to withstand the extreme rough road vibrations.
4.7	Exhaust System:	The exhaust system shall be of extra heavy-duty design. The muffler shall be of a semi-trailer truck type. All exhaust pipes and muffler shall be mounted and secured to withstand shocks & vibrations under the operating conditions specified herein. The exhaust stack shall be channeled for Horizontal discharge (Not vertical Not down ward) that is the Exhaust gas must be visible for the driver . Where the exhaust pipe runs, a heat shield (insulation) shall be placed for protection against heat damage
5	ELECTRICAL	
5.1	Charging System:	The charging system shall consist of a 24-volt and minimum of 45-AMp rated alternator. The alternator shall be mounted on the engine as close to the centerline as possible. Heavy-duty type BOSCH alternator is required.
5.2	Batteries:	All batteries shall be permanently identified or labeled with the SAE cold-cranking ampere (CCA) rating. Battery capacity must meet or exceed the engine manufacturer's minimum CCA requirement at 0°F. The acceptable size shall be two heavy-duty 12V, 170AH batteries.
5.3	Battery Mounting:	Batteries shall be mounted under the rear of the cab on the driver's side. Rubber padding, 7-10mm thick, in the bottom of the battery carrier, is required. Batteries in close proximity to the exhaust shall have heat shielding. Carriers, covers, hold-down & hardware shall have acid-resistant coating. Additional cable support covered with vinyl is necessary. Easily removable covers are necessary for regular battery servicing. All Batteries shall be the Rechargeable type .
5.4	Battery Cable Assemblies:	Routing of cables shall avoid heat, abrasion, and vibration. Grommets must be provided when the cable passes through holes in the sheet metal or frame. All bare metal edges shall be shielded.
	N.B: - The battery shall be equipped with an Earth disconnect switch (master switch) located near to the battery.	
6	LIGHTING SYSTEM	
		The lighting system shall consist of, but not limited to: <ul style="list-style-type: none"> • Two adjustable headlights with high and low beams, • Two parking lights,

		<ul style="list-style-type: none"> • Two stop and tail light combinations, • Interior overhead lights, • Instrument panel lights, • Back-up lights, • Reflectors • Clearance lights • Fog lights <p>All the above-mentioned lighting with wiring shall be in accordance with standard manufacturing practices and/or existing international uniform vehicle codes.</p>
<p>N.B: - Gravel protection grills shall be attached to all exterior lights. The grills shall be of the heavy duty type.</p>		
6.1	Direction signals and Hazard Warning Flashers:	<p>The vehicle shall be equipped with SAE class A type, or equivalent, double faced directional signals. This must be a lamp-type turn signal system capable of clearly indicating any intention of turning in either direction. In addition, four way hazard warning flasher shall be installed, which may be a combination turn signal-hazard warning flasher. Any system used shall project a flashing red light visible to the rear. The signal shall be plainly visible and of sufficient intensity to be effective in normal sunlight, or at night, from a distance of at least 152 meters to the front and rear of the vehicle.</p>
6.2	Direction Signal and Hazard Warning Flasher Switch Mounting:	<p>The required location for the turn signal switch shall be steering column mounted for convenient operation by the driver's left hand.</p> <p>The turn signal switch shall be of the self-canceling type construction. The turn signal indicator lights shall be visible and audible to the driver when the turn signal is activated. The turn signal switch shall be removable for service without removal of the steering wheel.</p>
6.3	Windshield Wipers:	<p>Minimum Dual electrically-operated, three speed windshield wipers and automatic windshield washers shall be installed.</p>
6.4	Horns:	<p>All vehicles will be equipped with <u>twin</u> diesel truck type of horns. The first type will be electrical with activation by the standard steering wheel button-mounted type. The second type will be air operated, with dual bugle horns mounted on the exterior top of the cab.</p> <p>There shall be an activating pull chain located inside the cab above the driver's door, or a foot operated activating device</p>
6.5	Circuit Protection:	<p>Battery cables, starter motor circuits, battery-to generator circuits, and ignition and horn circuits shall be wired without circuit protection. These circuits should utilize cable insulating materials and routing techniques that provided adequate protection against the possibility of short circuit.</p> <p>All other power feed circuits shall have adequate circuit protection, with each circuit having both primary and secondary protection devices. Cable and harnesses shall be routed along rigid sections of the cab or chassis. The wiring shall be secured, supported at intervals to prevent rubbing or chafing due to wire movement. Various types of plastic and metal clips, clamps, and ties may be used to support wiring harnesses. When metal support devices are employed, they must be covered or coated with a protective, non-conductive material.</p>

6.6	Starter Motor:	The motor that shall be mounted on the engine should be BOSCH starter motor with a minimum capacity of 6.5 kW.
6.7	Truck to Semi-Trailer Power Supply:	The truck-to- semi trailer power supply shall consist of a seven pole-way coupler power supply cord. ISO type coupler is preferred.
	CAB	
7	General Description:	The cab is to be equipped with all the necessary wiring, gauges, tubing and instrument panel for the efficient operation of the vehicle.
7.1	Cab construction (Fundamental):	<p>The cab shall be constructed so that the roof and floor are insulated against heat and cold. The cab shall be of, high roof, with two sleeper type, hydraulically tilt able, all steel construction.</p> <p>The cabin shall be equipped with double bed, mattress and curtains (with rails). Cabin Suspension shall be positively able to offset the extreme rough road shocks, vibrations and twists.</p> <p>The cabin front lower end clearance should be well above the minimum ground clearance.</p>
7.2	Instrument panel:	<p>The instrument panel shall be equipped at least with the following: -</p> <ul style="list-style-type: none"> • Panel lighting, • Speedometer and odometer (total and resettable) calibrated in kilometers and shall be the non-taco graph type, • Engine temperature gauge, • Lighting control switches, • Oil pressure gauge, • Air pressure gauge, • Engine RPM gauge, • Windshield wiper controls, • Direction signal lamp indicator, • Semi-trailer Air supply (control) valve, • Truck- Semi-trailer parking brake control valve, • Truck (only) parking brake control valve, • Fuel gauge, • Audible and visual oil pressure warning device, • Audible and visual water temperature warning device, • Audible and visual air pressure warning device, • Engine brake indicator. • Intake air indicator. • Gear shifting indicator • Insures cabin properly seat indicator • Door lock indicator <p>All gauges and controls must be labeled as to their assigned function in English (eg.. air pressure gauge, water temperature gauge, etc).</p>
7.3	Cab mounting Steps:	<p>All cabins with a door-sill more than 60cm off the ground shall be equipped with at least one step. Where the door-sill is at a height greater than 96cm from the ground a second step will be added. Additional steps shall be provided as the height increases.</p> <p>A step should be of sufficient size to accommodate both feet. The steps shall be solidly attached.</p>

7.4	Hand Holds:	At least one grab handle shall be affixed to the cab on both sides of the vehicle. As the number of steps increases, and if an offset ladder arrangement is used, hand-holds will become necessary.
7.5	Cab Tilting Pump and Hoses:	They should be extra heavy duty and compatible with the cabin size and located behind the cabin.
7.6	Air conditioning:	air conditioning is necessarily required
8	STEERING (FUNDAMENTAL):	The vehicle shall be equipped with left-hand-drive steering. ZF power steering (hydraulic power assisted) is required. In the event of a power steering failure a means must be provided for manual control of the vehicle . The hydraulic pump shall be directly driven by the Engine ; belt drive is not acceptable. The steering hose (pipe) must be passed through the radiator so as to cool by the fan.
9	POWER TRAIN	
9.1	CLUTCH:	The manufacture's standard clutch for use with the engine type supplied is acceptable. Detail technical data (Type, construction, function, capacity, etc.) of clutch system shall be provided with offer. The pressure plate will be self-adjusted and pull type diaphragm.
9.2	Transmission:	The transmission shall be ZF transmission extra heavy-duty, properly supported, Manual type with ten forward gears. It shall have a one-speed reverse. Detail technical data on ratios, torque, capacity, speed and proper gear changing controlling mechanisms and devises, etc shall be submitted with the offer. Current manufacturer's standard model is acceptable with extended warranty coverage.
9.3	Propeller Shaft:	The propeller shaft tubing must be of sufficient size and strength to carry the torque load imposed by the engine.
10	AXLES AND SUSPENSIONS:	
10.1	Front Axle:	The front axle shall be extra- heavy-duty, "I beam" axle. It shall have a min. rated capacity of 8000 kg. All spindles, kingpins, bushings, thrust bearings and wheel bearings shall be properly sized and matched with the front axle rating. The front axle shall also be equipped with a heavy-duty Stabilizer bar .
10.2	Front Springs:	The front spring shall be heavy-duty semi-elliptical type. Heavy-duty, double acting, telescopic shock absorbers shall also be installed. The shock absorber shall be compatible with the axle and suspension design. The manufacturer shall supply the pad rating and all details of springs installed.
10.3	Rear Axles:	The rear tandem (double) axles shall be of the full floating, through drive type with an inter-axle differential mounted on the forward axle, transmitted to the rear axle by a connecting shaft. It shall also be equipped with Air-Electrical operated differential lock controlled from the cab by the driver. The rear axles shall have a capacity of 13,000 KGS. Each (26,000kg in tandem). Provision shall be made that differential breathers are not easily blocked with dirt or mud. Magnetic fill and drain plugs shall be installed to the differentials.
10.4	Rear Suspensions:	Extra heavy-duty, cantilever tandem suspension springs shall be

		installed. Spring support brackets, plates, bolts, etc. shall be strong enough to withstand extreme rough road effects. The rear suspension shall be equipped with extra heavy-duty, double acting, telescopic shock absorbers. Axle stays (reaction bar), and torque arms shall be heavy duty. Cross members where axle stays (reaction bar) are fastened to shall be extra re-enforced.
11	WHEELS AND TIRES	
11.1	Wheels (fundamental):	Manufacture's current production heavy-duty single front and dual rear wheels and rims shall be accepted. All wheels and rims are to be interchangeable.
11.2	Tires (Fundamental):	The manufacturer shall supply 12.00 R20 ply rating, tube type, all steel radial (steel belts and steel carcass), on - off highway, heavy-duty tires. In addition the manufacturer shall furnish a spare wheel, tire, tube and flap. Tire inflator stem shall be easily accessible even on dual wheels.
11.3	Spare Tire Carrier:	A reinforced spare tire carrier shall be mounted at a suitable and easily accessible location. (Reserve tire carrier together for power and trailer truck should be designed and mounted under chassis towing trailer truck as fig indicated below).



12	CHASSIS	
12.1	Frame:	<p>The chassis frame shall be of the extra heavy-duty construction. It should be designed to withstand the heavy loads and extremely rough road, twists, shocks and vibrations. All tubing, wiring, lines and hoses shall be affixed to the chassis frame to prevent hanging loosely or dragging. They shall also be placed so as not to interfere with the propeller shaft operation. Chassis frame and cross members' technical details shall be provided with offer.</p> <p>Base of chassis frame thickness of trailer truck must be 16mm (see the attached I beam drawing and picture below).</p> <p>Chassis frame side wall (flat form) thickness of trailer truck must be 10mm (see the attached I beam drawing and picture below)</p>

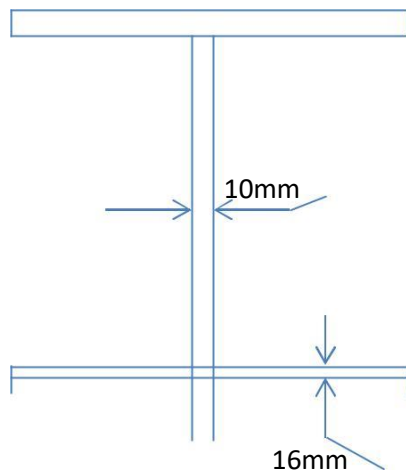

- Minimum thickness corrugated sheet of the side board must be 2mm. (See the attached picture below).

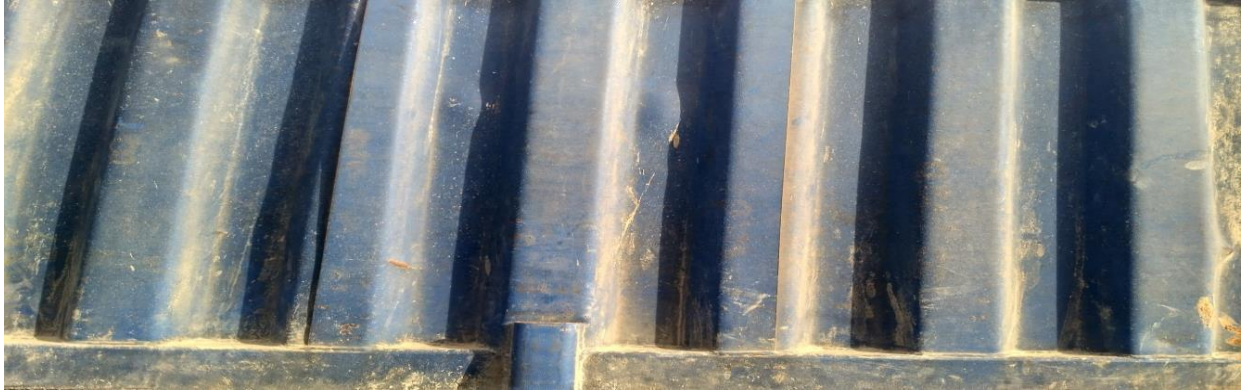

12.2	Trailer Leaf Spring:	
	<ul style="list-style-type: none"> No of leaf spring must be minimum 11 Leaf spring thickness 13mm 	<ul style="list-style-type: none"> With ABS Side plate height : 1000mm plate
	<ul style="list-style-type: none"> three axle , 13t*3, Kingpin : 3.5'' (90#) 	<ul style="list-style-type: none"> corrugated sheet minimum :2mm Made year : 2017
	<ul style="list-style-type: none"> Tire : 12.00R20, 12+1pieces 	<ul style="list-style-type: none"> Overall size : 12500×2600×3100mm
12.3	Wheel Base and Width:	The theoretical wheelbase (center of front axle to center of Bogie) shall not exceed 4,000mm. The overall width of the vehicle (excluding the side view mirrors) shall not exceed 2500mm.
12.4	Fifth Wheel:	The vehicle shall be equipped with heavy duty; fifth-wheel coupling that provides the link between a semi-trailer and the towing truck, tractor unit. The coupling should consist of a kingpin, steel pin on the front of the semi-trailer, and a horseshoe-shaped coupling device called a fifth wheel on the rear of the towing vehicle. The surface of the semi-trailer (with the kingpin at the center) shall be rotated against the surface of the fixed fifth wheel, which does not rotate.
12.5	Ground Clearance:	The minimum ground clearance of the fully loaded truck shall be 320mm .
12.6	Front Bumper:	A heavy-duty steel bumper shall be installed on the front of the chassis. The bumper shall span the complete width of the chassis.
12.7	Front Towing Device:	Each vehicle shall be equipped with towing device hook-ups at the front. The towing device hooks-ups shall be of sufficient strength to sustain emergency pulling without damage to the unit.
12.8	Under Coating:	All framing and chassis shall be coated with anti-rust and corrosion resistant.
13	AIR SUPPLY SYSTEM	
13.1	General Description:	The air supply system shall consist of a compressor, reservoir tanks, air lines, warning devices and all necessary coupling,

		valves and connections which would normally make up the air supply system. WABCO is preferred.
13.2	Air Compressor (PREFERABLY BENDIX):	The air compressor shall be of a pressure-lubricated type, using the engine lubrication system as the lubricant source. It shall be water cooled, drawn from the engine cooling system and the compressor output capacity shall be a minimum of 900 liters per minute at 1,900 RPM at sea level. The compressor shall be the Double-Barrel type.
13.3	Warning Device:	An audible and visual, low-air warning device shall be installed in the cabin. This device will activate when the air pressure drops below the required pressure to control the fully loaded vehicle as specified by the manufacturer.
13.4	Air Reserve Tanks:	The air reservoir tanks shall have a total minimum capacity of 85 liters. All reservoir tanks shall be equipped with safety and drain valves located in the bottom of the tank. Tanks will be mounted to allow easy access to drain. Air tank supports and clamps shall be sufficiently dimensioned to withstand excessive vibrations. Additional cable support covered with vinyl is necessary.
13.5	Air Lines:	All air lines shall be mounted to allow normal flow under normal operating conditions. They shall be routed away from places where heat build-up.
14	BRAKE SYSTEM	
14.1	General Description:	The brake system shall be an air-operated, manually adjustable & dual circuit air brake system with ABS. Brake Drum shall be balanced with manufacturer specifications. Brake size shall be of the greatest width available for the axle installed.
14.2	Service Brakes:	All service brakes shall be air-operated, with individual circuits for front and rear wheels. A quick-release and limiting valve should be incorporated on the front wheel brakes with the control within the driver's reach. Manual slack adjusters are required for each wheel. The service brakes shall be so designed that the driver is capable of controlling and holding a fully loaded truck-semi trailer combination on a 35 percent gradient. The braking system shall be capable of stopping the fully loaded truck-trailer within 12 meters from a speed of 32 kph on dry level roads. An emergency mechanical brake shall be incorporated to this system that will enable to stop the truck-semi-trailer combination in case of failure of service brakes. This shall be a spring loaded dual brake chamber design. Two separate lines, one for the service and another for emergency brake of the semi-trailer shall be installed. The parking brake should be air operated, spring brake chamber and a protection valve that is capable of holding the vehicle,

		fully loaded, on any grade on which it operates. Gravel protection should be necessarily installed to brakes chamber.
14.3	Engine Brake:	An air-operated engine brake with an operating switch located within the driver's reach should be installed. Retarding of the engine shall be effective enough on lower engine RPM by exhaust gas throttling, including TELMA and Jack brake.

14.4	Mobile Garage (Field Truck shop) For free: It Includes;			
NO.	PART NAME	UNIT	QTY.	MODEL
1	Van box	SET	1	3850*2050*2100 (Dimension in mm)
2	Generator & Air compressor machine (including workbench)	SET	1	
3	Welding machine	SET	1	ZX7-400
4	Drilling machine	SET	1	ZQ4120
5	Hydraulic Pneumatic jack	SET	1	50T
6	heavy duty pneumatic hammer	SET	1	-9999
7	Power starter 12V, 24V	SET	1	AW15
8	Grinding machine	SET	1	220V
9	Polishing machine	SET	1	GWS6-125
10	Working lamp	SET	1	90702A

15	TECHNICAL INFORMATION
	<p>The following technical information/data shall be given in detail:</p> <ol style="list-style-type: none"> a. Work shop Service and repair manuals b. Operators manual c. Part catalog d. Warranty booklets e. Vehicle identification and specification data cards <ul style="list-style-type: none"> • Engine, power rating, performance curves, fuel consumption etc., of truck, • Details of truck transmission, steering, frame, axles, suspension etc. • Details of pneumatic system, • Details of electrical components, wiring diagrams, instrumentation and controls, • Details of drivers cab and mounting, • Details of truck function, construction and dimensions, etc.
16	TOOLS AND ACCESSORIES:
	<ul style="list-style-type: none"> • 20m inflation hose For Each Truck • 30 ton hydraulic jack • Wheel spanners • Tire levers • Driver's complete tools kit • Jumper cable • Extension light (for driver use)

CONSUMABLE SPARE & FIELD KITS FOR TRUCKS

NO	PART DISCRPTION	Remark
1	Air cleaner element	
2	Fuel Filter Primary	
3	Fuel Filter Secondary	
4	Oil Filter	
5	Brake lining power	
6	Brake lining Rivet power	
7	Braking lining Trailer	
8	Brake lining Rivet Trailer	
9	Air dryer	
10	Wiper blade	
11	Clutch master cylinder	
12	clutch pedal return spring	
13	Intercooler Hose Big	
14	Cabin shock absorber	
15	Clutch booster	
16	Cabin shock absorber rear	
17	Cabin shock absorber front	
18	Front engine support	
19	Rear engine support	
20	AC Belt	
21	Water pump belt	
22	Alternator belt	For two years consumption
23	Intercooler hose small	
24	Foot brake valve	
25	Trailer control valve	
26	Clutch disc	
27	Pressure plate	
28	Foot brake relay valve	
29	Hand brake relay valve	
30	Trailer valve	
31	Fuel sensor	
32	Master switch	
33	Starter motor	
34	Alternator	
35	Gear box support rubber	
36	Turbo charger gasket	
37	Exhaust manifold gasket	
38	Intake manifold gasket	
39	Valve cover gasket	
40	Release bearing	
41	Air regulator(discharge valve)	
42	Turbo charger	
43	Belt tensioner	

I hereby certify to comply with all the above Technical Specifications.

Name of Company/Bidder

Signature over Printed Name of
Authorized Representative

Date